

# INSTALLATION AND INSTRUCTION MANUAL

# SS867/LCS869

SS867 - 100W REMOTE HAND HELD SIREN  
 LCS869 - 100W REMOTE HAND HELD SIREN w/ LIGHT CONTROLS

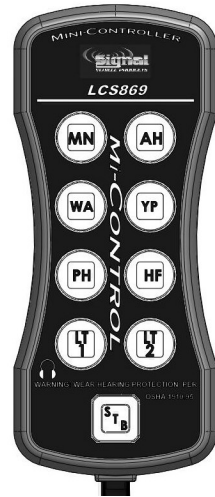
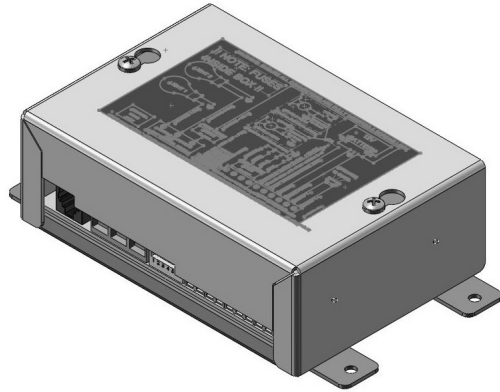

## NOTICE

Due to continuous product improvements, we must reserve the right to change any specifications and information, contained in this manual at any time without notice. Star Safety Technologies and/or the manufacturer make no warranty of any kind with regard to this manual, including, but not limited to, the implied warranties of merchantability and fitness for a particular purpose. Star Safety Technologies and/or the manufacturer shall not be liable for errors contained herein or for incidental or consequential damages in connection with the furnishing, performance, or use of this manual.



455 Rochester Street Avon, NY 14414  
 585-226-9500 (F) 888-478-2797  
 www.StarSafetyTechnologies.com

PLIT463 REV. C 2/28/24

## TABLE OF CONTENTS

INSTALLATION INFORMATION TABLE.....	i
GENERAL DESCRIPTION.....	1
INSTALLATION.....	1-11
INSTALLATION INFORMATION FORM.....	1
MOUNTING.....	2-4
RFI REDUCTION.....	2
LABEL INSERTION.....	4
ELECTRICAL CONNECTIONS.....	4-7
LIGHTING AND AUDIO TERMINAL DIAGRAM.....	4
RECOMMENDED WIRE SIZING CHART.....	5
SIREN WIRING DIAGRAM.....	7
DIP SWITCH OPTIONS.....	8-9
PROGRAMMABLE OPTIONS.....	10-11
SYSTEM RESET ◀◀◀.....	11
OPERATION.....	12-14
POWER/STANDBY.....	12
AUDIO CONTROLS.....	13-14
AUXILIARY INPUT.....	14
LIGHT CONTROLS.....	14
SERVICE.....	15-18
TROUBLESHOOTING.....	15
ERROR CODES.....	16
FUSES.....	16
SPECIFICATIONS.....	16
PARTS.....	17
WARRANTY.....	17
RETURNED MATERIALS AUTHORIZATION FORM.....	18

## Installation Information

MODEL: \_\_\_\_\_  
 AMP S/N: \_\_\_\_\_  
 CONTROL HEAD S/N: \_\_\_\_\_  
 PURCHASE DATE: \_\_\_\_\_  
 INSTALLATION DATE: \_\_\_\_\_  
 INSTALLER: \_\_\_\_\_  
 DEALER: \_\_\_\_\_

### SIREN OPTION DIP SWITCHES

- |   |  |
|---|--|
| <input type="checkbox"/> Negative Auxiliary Switching | <input type="checkbox"/> Horn disabled in HF   |
| <input type="checkbox"/> Manual Ramp Down Disabled    | <input type="checkbox"/> Restricted Audio Mode |
| <input type="checkbox"/> HF on Start-up               |  |



## General Description

The SS867 and LCS869 sirens are premium remote systems that combine the siren amplifier, the siren controls, and light controls (*LCS869 only*) all in one system. A single slim-line hand-held remote control head contains all of the controls. The LCS869 also incorporates light controls for the vehicle. The control head contains illuminated switches that change color to indicate status. The face of the control head is sealed around every push button to help prevent liquid from entering the electronics. The amplifier is a 100W siren amplifier unit designed for single 100W speaker use.

The control head contains several distinct controls for operation of the siren. In addition, the LCS869 also has two push buttons that allow control of lighting or auxiliary functions.

The SS867 and LCS869 is designed to allow maximum versatility in mounting. The hand-held controller is remote from the siren amplifier and light relay control box, creating a compact user interface that can be mounted onto the dashboard, overhead, or in the center console. The hand-held controller comes with a strip of hook and loop fastener for mounting. The amplifier box can then be mounted remotely in the trunk, under the dashboard, under the seat, or wherever convenient.

Standard siren operating modes include Wail, Yelp, and Phaser. A Manual button allows tone toggle operation and manual siren control. The Air Horn button and/or vehicle horn switch will override any siren tone. Optionally, the vehicle horn switch can be connected to perform the Manual or Hands-Free function via an auxiliary input. Six option switches allow the unit to be customized to the operators' needs. DIP switch options include: AUX polarity, Manual "ramp down", Hands Free option at boot, immediate cyler in Hands Free, and Restricted Audio mode. Programming options include 22 optional siren tones, momentary switching, and gun lock switching.

## Installation Notes

Proper installation of the unit is essential for years of safe, reliable operation. Please read all instructions **before** installing the unit. Failure to follow these instructions can cause serious damage to the unit or vehicle and may void warranties.

**Qualifications** - The installer must have a firm knowledge of basic electricity, vehicle electrical systems, and emergency equipment.

**Keep These Instructions** - Keep these instructions in the vehicle or other safe place for future reference. Advise the vehicle operator of the location.

**Unpacking** - Immediately inspect the contents for shipping damage. If any damage is found, alert the carrier immediately.

Contents should include:

- 1 - hand held remote control head with 10' cable
- 1 - amplifier (and light control box for the LCS869)
- 1 - hook & loop strip for mounting control head
- 1 - label set
- 1 - installation and operating instructions

Please contact your supplier immediately if any components are missing.

## Mounting

### RFI REDUCTION

Prior to installation, please review the information below pertaining to unit location and wire routing. The following steps are recommended when installing, to help reduce RFI:

1. Make sure that the amp is securely attached to good chassis ground (i.e. no paint in-between the chassis and the grounding terminal).
2. Keep the siren control head and the police radio as far away from one another as is practical.
3. Keep the siren amp and the police radio remote mount portion and/or antenna wire as far away from each other as is practical.  
**2 FT minimum!!**
4. Check that the police radio antenna wire makes a right angle from the back of the police radio and runs on one side of the vehicle. The communications cable for the siren should make a right angle out of the back of the control head and exit in the opposite direction from both the police radio antenna wire and the police radio power wires.
5. Excess communication cable from the control head to the amp should be tightly bound back near the amplifier box. ***Do not mount bundle near police radio components!!***
6. The siren and the police radio MUST not share a power or ground wire, they should meet only at the battery.

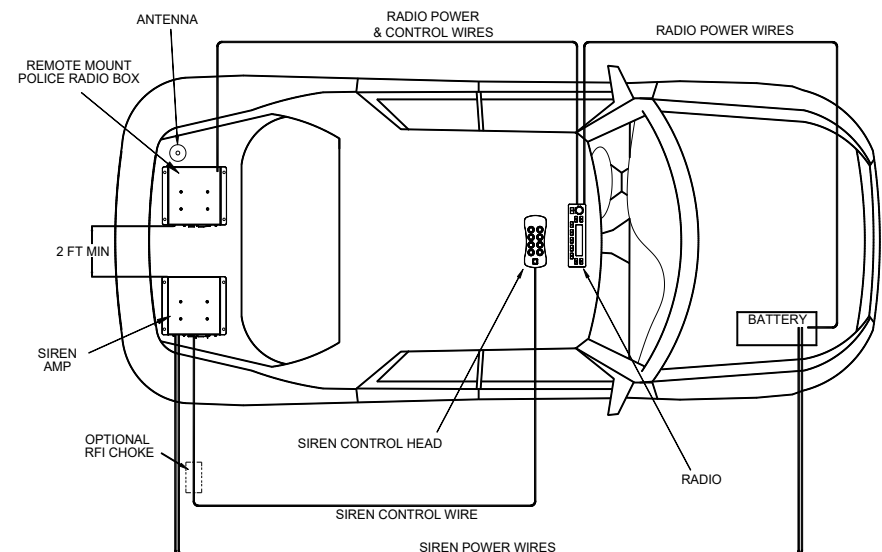

### SAFETY PRECAUTIONS

For the safety of the installer, vehicle operator, passengers and the community please observe the following safety precautions. **Failure to follow all safety precautions and instructions may result in property damage, injury or death.**

**WARNING**

DO NOT mount in air bag deployment area. Devices should be mounted only in locations listed in SAE standard J1849. Controls should be placed within convenient reach of the driver. Assure clearances before drilling in vehicle. Sound levels produced by attached speakers can cause permanent hearing loss.

### SIREN AMPLIFIER & RELAY CONTROL BOX

- The SS867/LCS869 amplifier should be mounted in a dry location such as the driver compartment firewall, under the seat, or in the trunk.

**Water damage will void the warranty!!!**

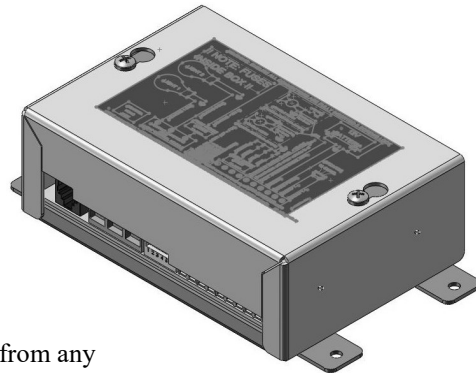

- Do not mount the amplifier in the engine compartment or in an area that would be allowed direct exposure to weather elements.
- Choose a mounting location away from any air bag deployment areas.
- Assure adequate ventilation to prevent overheating.

- The amplifier unit is provided with a mounting flange that contains four 3/16" holes.
- Using the amplifier unit itself as a template, mark the location of the four mounting holes to be drilled.
- Check for obstructions behind the mounting hole locations and drill the four mounting holes and secure the amplifier using appropriate hardware (not supplied).

### MOUNTING THE HAND-HELD CONTROLLER

- The SS867 AND LCS869 include a strip of hook & loop fastener that can be used for storing the hand-held controller when it is not in use.
- Select a location so that the cable does not interfere with the vision of the driver or the operation of any controls, including, but not limited to, the steering wheel, gear shifter, and/or airbag.
- Select a surface that is relatively flat to allow good adhesion of the fastener to the vehicle as well as providing enough of a surface to adequately secure the hand-held unit.

### Label Insertion

This siren comes with labels pre-installed on the Standby and siren function buttons (STB, MN, AH, WA, YP, PH, and HF). If you are installing the LCS869, the LT1 and LT2 buttons are not shipped with labels.

At any time during installation, labels can be removed or inserted into the buttons to fit your needs. The product is shipped with 42 alternate labels with various abbreviations for these push buttons. Select the desired label inserts (provided). Insert the label into each button and tuck it under the lip of the switch. Labels can be rotated sideways or upside down if desired.

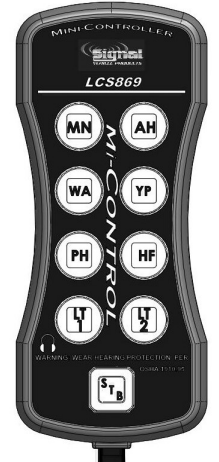

Cut-View

### Electrical Connections

The Wiring Guide chart on the following page lists the functions of the Lighting and Audio terminals shown below.

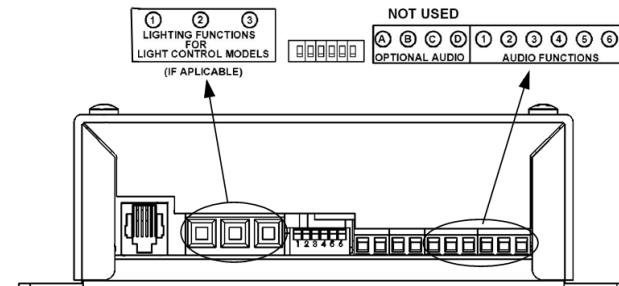

### Wire Size and Termination

Examine the charts below to determine the proper gauge of the wire you should use. Please review the following recommendations to follow when making your installation:

- Use only high quality crimp connectors.
- All conductors should be constructed of stranded copper with thermoplastic insulation.
- Make sure all connections are tight.
- Route wiring to prevent wear, overheating, and interference with air bag deployment.
- Use grommets and sealant when passing through compartment walls.
- Minimize the number of splices to reduce voltage drop.
- Ground connections should only be made to substantial chassis components, preferably directly to the negative of the vehicle battery.
- Install and check all wiring before connection to vehicle battery.
- **CAUTION: All wires should be rated for at least 125% of their maximum current load. All wires connected to the positive terminal of the battery should be fused at the battery for their rated load.** The load can be calculated by adding all lamp wattages and dividing by 13. Load (Amps) = Total Watts / 13 volts. Do not use 1/4" diameter glass fuses, as they are not suitable for continuous duty above 20 amps.

### WIRING GUIDE

Input/Output	Description	Typical color	Typical current
Audio 1	Ignition Switched Power	YELLOW	0.14 AMPS
Audio 2	AUX	GREEN	0.002 AMPS
Audio 3	Battery Negative/Ground	BLACK	11 AMPS
Audio 4	Siren Power	RED	10 AMPS
Audio 5	Speaker 1	BROWN	4 AMPS
Audio 6	Speaker 2	BROWN	4 AMPS
Lighting 1	LT1 Output	ANY	MAX 30 AMPS
Lighting 2	LT2 Output	ANY	MAX 30 AMPS
Lighting 3	Power for Lights	RED	MAX 30 AMPS

### RECOMMENDED WIRE GAUGE

Current	10'	20'	25'
< 2.0A	22 AWG	18 AWG	18 AWG
4.0A	18 AWG	16 AWG	16 AWG
5.5A	18 AWG	16 AWG	14 AWG
8.0A	16 AWG	14 AWG	14 AWG
12.0A	16 AWG	12 AWG	12 AWG
14.0A	14 AWG	12 AWG	10 AWG
18.0A	14 AWG	10 AWG	10 AWG
20.0A	12 AWG	10 AWG	8 AWG
30.0A	8AWG	8AWG	8AWG
40.0A	8AWG	8AWG	2 x 8AWG

Review the chart to the right that indicates the recommended wire gauge, based upon the length of the wire run and the current that will pass through the wire.

Wiring connections to the siren are all made through various terminals on the rear of the amp.

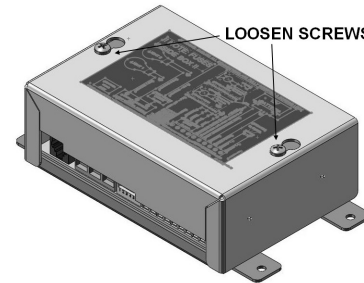
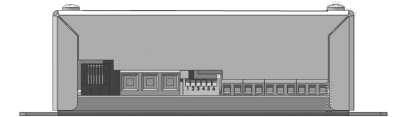

You will need to remove the siren cover to access the terminal screws.

Loosen (but do not remove) the two screws that secure the top of the amplifier.

Carefully slide the top of the amp towards the rear of the siren so you can lift the top off of the screws.

Once the top has been removed, locate the screws that secure the wires to each terminal.

The function of each terminal is shown in the diagram on the following page.

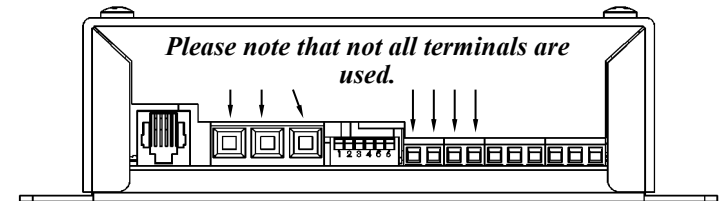
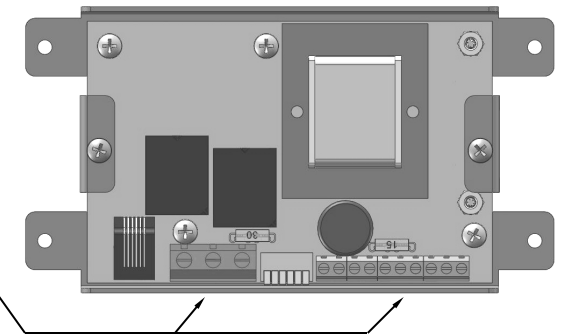

### MANDATORY ELECTRICAL CONNECTIONS

**Power** - Connect a 10-16VDC ignition switched power source to the AUDIO FUNCTIONS terminal labeled ① in the diagram on the following page. **⚠ (You MUST connect this wire!!)**

**Ground** - Connect AUDIO FUNCTIONS terminal ③ to the negative terminal of the battery.

**Audio Power** - Connect AUDIO FUNCTIONS terminal ④ to the positive terminal of the battery through a 15A fuse. **⚠ (You MUST connect this wire!!)**

**Speaker** - Connect AUDIO FUNCTIONS terminals ⑤ and ⑥ to speaker.



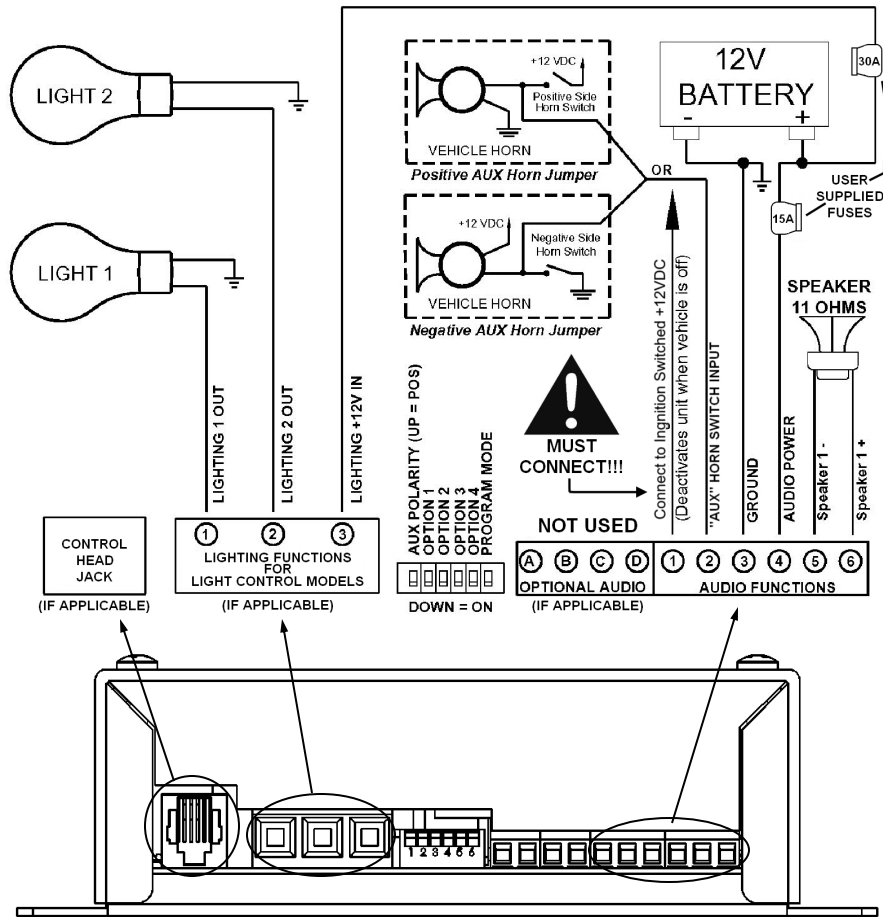

### OPTIONAL ELECTRICAL CONNECTIONS

**AUX Input** - If you will be using the Hands Free option to activate and change siren tones with the vehicle horn, connect AUDIO FUNCTIONS terminal ② to the horn switch. Be sure that you have set DIP switch #1 for the correct polarity (see page 8).

**Lighting Power** - (LCS869 Only) If you will be controlling lights with this unit, connect LIGHTING FUNCTIONS terminal ③ to +12VDC through a 30A fuse.

**Lighting Output** - (LCS869 Only) If you will be controlling lights with this unit, connect LIGHTING FUNCTIONS terminal ① and ② to the lights (or devices) that you would like controlled with buttons LT1 and LT2, respectively (30A total MAX).

### DIP Switch Options

The SS867 AND LCS869 have several options that can be selected during installation using the DIP switches located on the back of the amplifier case. *These options should be set before installation of the unit.*

#### Siren option DIP switches

- Auxiliary Input Polarity
- Manual Ramp Down Disable
- Hands Free Mode at Boot
- Immediate cycler in HF Mode
- Restricted Audio Mode

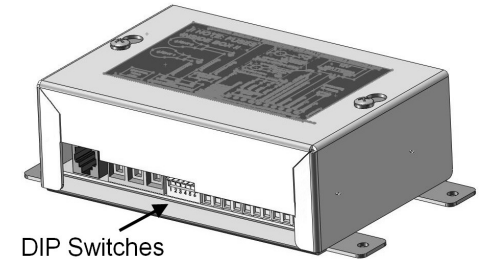

DIP SWITCH	FUNCTION	UP (Off) (default)	DOWN (On)
1	AUX Polarity	Positive switching	Negative switching
2	Manual Ramp Down Disable	Manual tone ramps down	Manual tone silenced on release
3	Hands Free Mode at Boot	HF mode off at power up	Siren in HF mode at power up
4	Immediate cycler in HF mode	3 sec. Horn, then cycler in HF mode	Immediate cycler in HF mode
5	Restricted Audio Mode	Normal operation (siren tones avail.)	No siren tones avail. (only air horn tones)
6	Program Mode	Normal operation	Programming mode

#### DIP Switch 1 - Auxiliary Input Polarity

Applying a positive voltage to the green wire normally activates the auxiliary function (Air Horn standard/MANUAL function optional). To have the AUX function instead activate when the green wire is connected to ground (negative), flip DIP switch #1 into the DOWN (On) position (as pictured to the right).

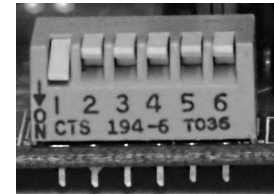

#### DIP Switch 2 - Manual Ramp Down Disable

Under the default setting, pressing the Manual button will produce a tone that “ramps” or “winds” up. When the MN button is released, the tone will gradually “ramp” or “wind” down. If you would like the tone instead to immediately cease once the MN button is released, flip DIP switch #2 into the DOWN (On) position (as pictured to the right).

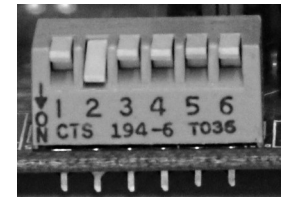

#### DIP Switch 3 - Hands Free Mode at Boot

If you wish to have the siren automatically activated in Hands Free Mode when the unit is powered up, you can select this option. Place DIP switch #3 into the DOWN (On) position (as pictured to the right).

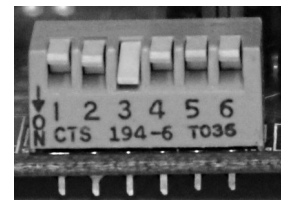

### DIP Switch 4 - Immediate Cycler in HF Mode

The standard setting for Hands Free mode (HF) requires you to press and hold the vehicle horn (air horn sounds as well) for 3 seconds to activate the HF cycler mode. Once in HF cycler mode, only a brief activation of the vehicle horn will then cycle the siren tone output.

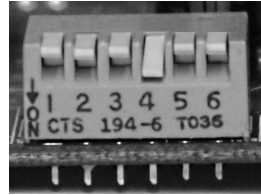

If you wish to eliminate the 3-second requirement for HF cycler activation and have it activated immediately when the vehicle horn is pressed, set DIP switch #4 into the DOWN (On) position (as pictured above).

### DIP Switch 5 - Restricted Audio Mode

Some municipalities restrict the use of sirens for various applications. If this siren is being used in an application in which sirens are NOT permitted and you wish to re-program the standard tones, flip DIP switch #5 down (as pictured to the right). This will replace the four siren tones (Wail, Yelp, Phaser, and High-Low) with four different Air Horn tones that are generally accepted in most municipalities (*verify regulations with local authorities*). Review the chart below to see the replacement tones.

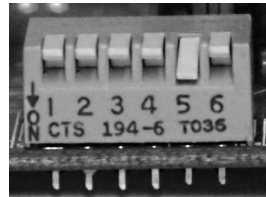

Please note that if this option is set, you CANNOT program the siren tones as described in the **Programmable Options** section (only the AUX wire and AH buttons will be programmable).

#### Restricted Audio Mode

Siren Button	Air Horn Replacement Tone	MN Step-Up Air Horn Tone
Wail	Double Post Pop Air Horn	Single Air Horn
Yelp	Single Air Horn	Single Quick Air Horn
Phaser	Single Quick Air Horn	Two-Tone Air Horn
Ramp Up (MN Button)	Rapid Air Horn	N/A

## Programmable Options

In addition to options set by DIP switches, the SS867 and LCS869 also have several options that can be selected during installation through “programming”.

### Programming Instructions

To program the advanced features, follow these steps:

- Power the unit up.
- Place the unit in “Programming Mode” by flipping DIP switch #6 down as shown to the right. The controller should beep a couple tones and the keypad should quickly flash a couple times.
  - Programming optional tones for the **MN** or **AH** buttons: (Manual & Air Horn)
    - Press **and hold** the **MN** or **AH** button. (The currently selected tone is played)
    - While holding the **MN** or **AH** button, press and release the **STB** button to cycle through the tones available. *Review the chart on the next page for a list of optional tones.*
    - Release the **MN** or **AH** button.
  - Programming optional tones for the **Aux wire** (typically activated using the steering wheel horn).
    - Press **and hold** the **steering wheel horn**. (The currently selected tone is played)
    - While holding the steering wheel horn, press and release the **STB** button to cycle through the tones available. *Review the chart on the next page for a list of optional tones.*
    - Release the **Steering wheel horn**.
  - Programming optional tones for the **WA, YP, or PH** buttons:
    - Press **and release** the **WA, YP, or PH** button. (The currently selected tone is played)
    - Press and release the **STB** button to cycle through the tones available. *Review the chart on the next page for a list of optional tones.*
    - Press and release the **WA, YP, or PH** button to save the tone. *Note: the Manual step up tone for WA button is the YP tone and for the YP button is the PH tone.*
  - Programming an optional **PH Step up tone**: (Phaser step up)
    - Press **and release** the **PH** button, press and release the **MN** button. (The currently selected tone is played)
    - Press and release the **STB** button to cycle through the tones available. *Review the chart on the next page for a list of optional tones.*
    - Press and release the **PH** button to save the tone.
  - Programming optional switching modes for the **LT1** or **LT2** buttons (Lights 1 & 2):
    - Press **and release** the **LT1** or **LT2** button. (The button will repeatedly flash 1-4 times corresponding to which switching mode the button is set for.) *Review the chart on the next page for a list of optional switching modes.*
    - Press and release the **STB** button to cycle through the available functions.
    - Press and release the **LT1** or **LT2** button to save the switching mode.
- Repeat from step 2 for any other buttons you wish to program.
- When done you **MUST** flip the Program dip (6) switch up to save the changes and exit programming mode.

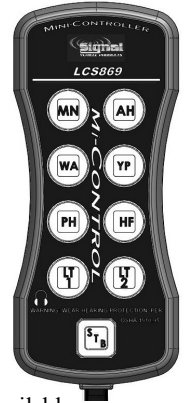
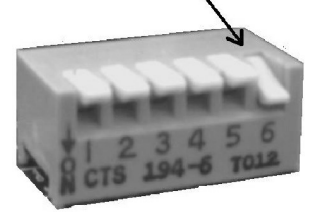

### Optional Siren Tones

Any of the siren tones, including the Manual, Air Horn, and AUX, can be replaced with one of several different optional tones. Review the charts to the right for the list of tones for each set of buttons (functions).

The top chart lists the tones that can be set for the three siren buttons (normally defaulted for Wail, Yelp, and Phaser).

The second chart lists the tones that can be set for the *MN* button and the function controlled by the AUX wire.

The third chart lists the optional tones the *AH* button can be programmed for.

### Optional Light/Function Settings (LCS869 Only)

The two Light Control Buttons on the LCS869 are normally standard On/Off buttons. When the unit itself is initially powered up, the buttons are “Off”. Pressing them once turns them “On”. Pressing them again turns them “Off”.

If desired, you can program these buttons to function 3 other ways:

*Normally Closed*—“On” when the unit is powered up. Pressing the button will turn it “Off”.

*8-Second Gun Lock*—Pressing the button will activate it for 8 seconds. Then it will turn off.

*Momentary*—The button is “On” only when you hold it in. Releasing it deactivates the button.

### ▶▶▶▶ System Reset ◀◀◀◀

If you would like to reset all of the siren programming options to their defaults:

- Place the unit in “Programming Mode”
- Press the *MN* and *AH* buttons for six (6) seconds. All siren tones will stop and the control head will buzz.
- Release the buttons and flip DIP switch #6 Off to exit Programming Mode.

TONE SIREN BUTTONS	
1	WAIL ( <i>WA default</i> ) §, *
2	YELP ( <i>YP default</i> ) §, *
3	PHASER ( <i>PH default</i> )
4	TWO TONE ( <i>Button 3 Step Up default</i> )
5	MECHANICAL WAIL (FIRE ENGINE)
6	HOOT
7	RAPID HOOT
8	AIR HORN & YELP
9	GHOST
10	RAPID GHOST
11	SINGLE AIR HORN
12	SINGLE QUICK
13	DOUBLE POST POP AIR HORN
14	TWO TONE AIR HORN
15	STANDARD AIR HORN

TONE AUX WIRE & MANUAL BUTTON	
1	STANDARD AIR HORN ( <i>AUX default</i> )
2	LOW FREQUENCY AIR HORN
3	RAPID AIR HORN
4	AIR HORN II
5	DOUBLE POST POP AIR HORN
6	SINGLE AIR HORN
7	SINGLE QUICK AIR HORN
8	TWO TONE AIR HORN
9	MANUAL ( <i>MN default</i> ) *
10	MECHANICAL MANUAL (FIRE ENGINE)

TONE AIR HORN BUTTON	
1	STANDARD AIR HORN ( <i>default</i> )
2	LOW FREQUENCY AIR HORN
3	RAPID AIR HORN
4	AIR HORN II
5	DOUBLE POST POP AIR HORN
6	SINGLE AIR HORN
7	SINGLE QUICK AIR HORN
8	TWO TONE AIR HORN

§ = SAE approved  
\* = California Title 13 approved

LIGHT CONTROL BUTTONS	
1	NORMALLY OPEN RELAY ( <i>default</i> )
2	NORMALLY CLOSED (On at Boot)
3	8 SECOND GUN LOCK
4	MOMENTARY

## Operation

### GENERAL

This unit is designed for easy operation under the stress associated with high-speed pursuit. All light and siren functions are activated through the hand-held controller.

### POWER/STANDBY

The main activation of this unit is controlled by the *STB* button located at the bottom of the hand-held controller. To activate the unit, press and hold the *STB* button until it beeps, then release it (approximately ½ second). The buttons will illuminate and the unit will be on, awaiting you to activate a function.

To turn the unit into Standby mode (deactivates buttons, disables AUX wire, and powers down lights), press the *STB* button for 2 seconds and release it.

Please note that even when in Standby mode the siren will still draw a small amount of power (150mA). When hooked up in the recommended fashion, this siren is connected to an ignition switched power source so that when the vehicle’s ignition is turned off, the unit is powered down (draws no power). When the vehicle’s ignition is turned on, the unit will return to the state it was in (Standby or On) when the ignition was turned off.

The *STB* button can also be used to cancel the current siren tone. Briefly pressing the *STB* button (less than 1 second) will stop all tones and lights.

The *STB* button also allows you to set backlighting and beep volume. To access this programming mode, hold down the *STB* button down for three seconds and the top 4 buttons (*MN*, *AH*, *WA* and *YP*) illuminate. Continue holding the *STB* button down and proceed as follows:

- Press the *MN* (dimmer) or *AH* (brighter) buttons to adjust the button backlighting.
- Press the *WA* (quieter) or *YP* (louder) buttons to adjust the volume of the button beep (Off→Quiet→Medium→Loud→Extra Loud).
- Releasing the *STB* button will place the unit into standby mode.
- The changes will be saved and used the next time the unit is brought out of Standby mode.

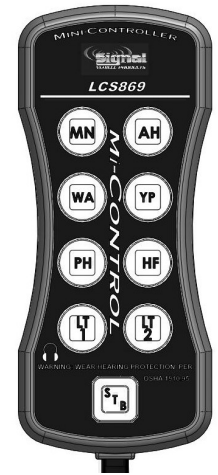



## AUDIO CONTROLS

The top three rows of push buttons on the hand-held control head allow full siren operation. When not activated, these buttons are backlit in green for nighttime viewing. When activated, an audible beep is heard, and the backlighting turns red.

### MN (Manual)

When the unit is on and is not producing any siren tones (including Hands Free Mode), this momentary push button switch provides a manually rising and falling siren tone while being pressed.

With the Wail, Yelp, or Phaser mode selected, pressing the *MN* button will “step” the siren up to the next button’s programmed tone:

(Wail → Yelp → Phaser → PH Step Up)

These quicker tones are used to momentarily alert motorists at intersections and very highly congested areas. Pressing the button once changes to the next faster tone. Pressing the *MAN* button again, reverts the siren back to the original tone.

### AH (Air Horn)

This momentary push button switch provides a simulated air-horn tone while pressed. It is useful at intersections or in high noise areas. This tone will override all other siren tones. (See page 5 to program optional tones.)

### WA (Wail)

A normal rise-fall tone used on highways and areas with low traffic or constant traffic flow. (See page 5 to program optional tones.)

### YP (Yelp)

A rapid warble tone used in light to moderately congested areas. (See page 5 to program optional tones.)

### PH (Phaser)

Ultra-fast warble tone used for maximum attention in highly congested areas. (See page 5 to program optional tones.)

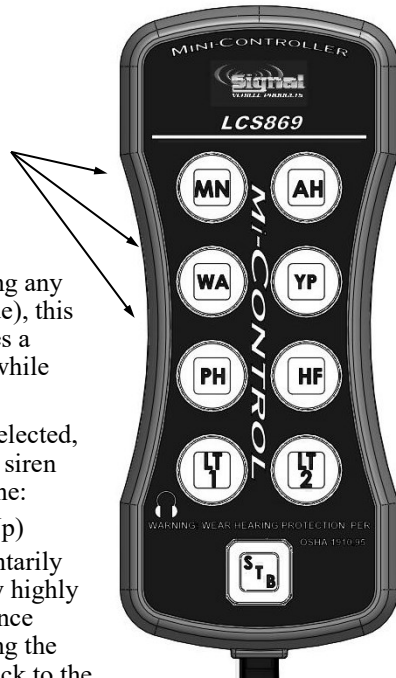

## HF (Hands Free) and AUX (Auxiliary Wire)

This mode is also known as Horn Ring Cyclor and require connection of the AUX wire. The AUX wire is typically connected to the vehicle horn switch and has a number of functions. See page 3 to select positive (+12VDC) or negative (ground) switching.

When the unit is on and in any mode, activating the AUX wire (i.e. pressing the vehicle’s horn) will produce the Air Horn tone (or any other optional tone you have programmed the AUX wire for—see pages 4-5).

If you are in HF mode, pressing the vehicle’s horn will activate the Air Horn tone for 3 seconds and then will start the *Hands Free Cyclor* mode (see page 3 for *Immediate Cyclor in HF Mode*):

(Wail → Yelp → Phaser → Silent)

- The siren will first produce the tone you have programmed for the WA (Wail) button.
- Pressing the vehicle’s horn a second time will cycle the siren to the tone you have programmed for the YE (Yelp) button.
- Pressing the vehicle’s horn a third time will cycle the siren to the tone you have programmed for the PH (Phaser) button.
- Pressing the vehicle’s horn a fourth time will silence the siren and leave it in HF mode to start the cycle again.

## LIGHT CONTROLS

The bottom row of push buttons on the hand-held control head allow for operation of two lights (or auxiliary devices) of up to a combined 30 amps max. When not activated, these buttons are backlit in green for nighttime viewing. When activated, an audible beep is heard, and the backlighting turns red.

These switches (LT1 and LT2) are normally off when the unit is powered up. See page 5 for details on programming either of these buttons for any of the following optional modes:

- On at boot (i.e. normally closed)
- 8-second timed On
- Momentary Operation

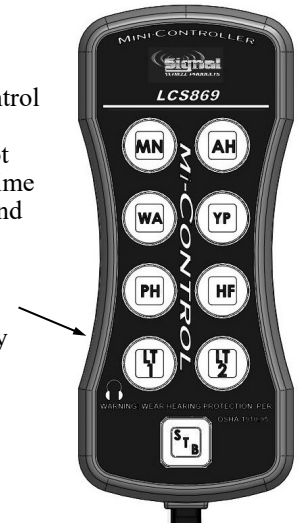

**Testing - Test all siren functions after installation to assure proper operation. Test vehicle operation to assure no damage to vehicle.**



## Troubleshooting

Symptom	Possible Cause	Check
No power	Power switch not turned on Check power Wires  Fuse or circuit breaker blown	Does back-lighting come on? If not hold STB button for 3 sec. Is power hooked up backwards? Positive ground vehicle? Are the negative leads connected to a good ground? Measure voltage between ground & +12v terminal Measure voltage between ground & ignition switched terminal. Check Fuse under amplifier cover. Check external fuses or circuit breakers
No siren tone and flashing hand held unit	High voltage or low voltage protection	Measure voltage between ground & ignition switched terminal. The input voltage must be between 10 & 16V.
No siren tone and hand held unit NOT flashing	Bad speaker or speaker wiring (open)  Blown Fuse	Disconnect the speaker at the amplifier, and turn a tone on. If you hear sound something is wrong with the speaker or wires running to the speaker. Check fuse inside amp housing
No siren tone and hand held unit FAST flashing	Speaker or speaker wiring short	Disconnect the speaker at the amplifier, and turn a tone on. If you hear sound the siren is working correctly and you have a short in the speaker wiring or speaker itself.
Distorted siren sound	Speaker assembly loose Intermittent AUX input connection Low or high vehicle voltage	Is the speaker loose? Is the Aux. Input used and wired properly?  Input voltage must be between 10 & 16 volts while siren is on.
Intermittent siren tone	Low voltage protection  Circuit breaker in supply connection Shorted speaker or speaker wire	Wires connected tightly to the back of the unit? Loose connection on a power lead? Input greater than 10V with the siren turned on? Is a circuit breaker used with at least a 30A rating? Does the speaker have water damage, or is a wire pinched?
AH function or MN function stuck on	Aux. Input improperly connected of Aux. Input Polarity Option set wrong	Remove the Aux input wire at the amp. Does the problem stop? If so the aux polarity may be set wrong or the aux wire may be wired incorrectly
Wrong siren tone	Option accidentally changed	See programming and setting to defaults section
Keypad beep not working	Keypad beep (Buzzer) disabled	See buzzer volume adjust
No light function	Blown fuse	Check fuse inside amp Check external fuses

(Troubleshooting CONT'D)

## ERROR CODES

This unit can detect certain undesirable conditions and will alert the user. The lighting controls will still function, but all audio functions are disabled until the error is corrected.

- The entire unit will flash SLOWLY if either over or low voltage is detected.
- The unit will flash FAST if a short is detected.

## FUSES

This unit is equipped with two internal fuses. To locate them remove the cover from the siren and review the diagram to the right.

The siren itself utilizes a 15 amp fuse. If this fuse blows, replace it with a fuse of the exact same value. If the fuse blows a second time, there is likely an internal problem in the siren and you should contact the Customer Service Department to obtain an RMA number so the siren can be sent in for repair.

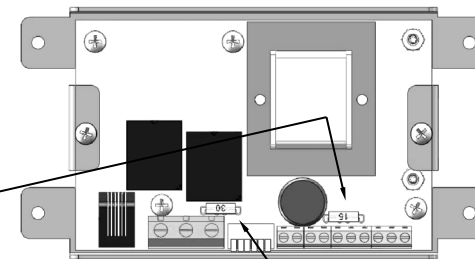

The light outputs are protected by a 30 amp fuse. If this fuse blows, the problem is likely external to the siren. Check the wiring to your lights and the lights themselves for a short. Once found and repaired, replace the fuse with another 30 amp fuse and activate the lights with the controller to verify you have addressed the issue.

## Specifications

Input Voltage	10 - 16 VDC (negative ground)
Audio Input Current	8 Amps @ 13.6 VDC (100W speaker)
Standby Current	Enable wire off 0mA Backlighting on: 260 mA Backlighting off: 150 mA
Output Power	105 WATTS RMS MAX. (15.0 VDC - single 100W speaker)
Siren Frequency	675Hz - 5kHz
High Voltage Protection	> 16 VDC will cause siren output to cease, resume at normal < 10 VDC will cause siren output to cease, resume at normal
Short Circuit Current	50 AMPS (supply circuit must be capable of supplying this)
Operating Temperature	-15° F to +140°F
Size	AMP: 5.75" x 3.75" x 2.0" Control Head: 4.5" x 2" x 0.75"
Boxed Weight	2.25 lbs.

## Parts

Part	Description
SLCS860-AMP	SS867 Amplifier Only
SLCS860-1-AMP	LCS869 Amplifier Only
SSS867-CH	Hand-Held Control Head for SS867
SLCS869-CH	Hand-Held Control Head for LCS869
30008-22	25' Communication Cable for Control Head and Amp*
30041-52	F-F Jack for Communication Cable
BCK-30008-22	Extension Cable Kit (included 25' cable and F-F jack)
P30053-41	Amplifier Case Screws
P30028-27	15 Amp Automotive Blade Fuse
P30028-28	30 Amp Automotive Blade Fuse for Amplifier
P30033-13	Output FET
PLABLCS860-1	Button Label Sheet
P30209-4	Hook Fastener
P30209-5	Loop Fastener

\* **CAUTION:** *These are not a standard telephone cables and CANNOT be replaced with one.*

## Warranty

### ONE YEAR LIMITED WARRANTY

Star Safety Technologies warrants this product against factory defects in material and workmanship for one year after the date of manufacture. The owner will be responsible for returning to the Service Center any defective item(s) with the transportation costs prepaid. The manufacturer will, without charge, repair or replace at its option, products, or part(s), which its inspection determines to be defective. Repaired or replacement item(s) will be returned to the purchaser with transportation costs prepaid from the service point. A copy of the purchaser's receipt must be returned with the defective item(s) in order to qualify for the warranty coverage. Exclusions from this warranty include, but are not limited to the finish. This warranty shall not apply to any product, which has been altered, such that in the manufacturer's judgment, the performance or reliability has been affected, or if any damage has resulted from abnormal use or service.

There are no warranties expressed or implied (including any warranty of merchantability or fitness), which extend this warranty period. **The loss of use of the product, loss of time, inconvenience, commercial loss or consequential damages, including costs of any labor, are not covered.** Star reserves the right to change the design of the product without assuming any obligation to modify any product previously manufactured.

This warranty gives you specific legal rights. You might also have additional rights that may vary from state to state. Some states do not allow limitations on how long an implied warranty lasts. Some states do not allow the exclusion or limitation of incidental or consequential damages. Therefore, the above limitation(s) or exclusion(s) may not apply to you.

If you have any questions concerning this or any other product, please contact our **Customer Service Department** at (585) 226-9500.

## RETURN

If a product must be returned for any reason, please fill out the form on the back of this page, then call 585-226-9500 option #3 (Repair Department). Once the product is deemed defective by us, an RMA number (Returned Materials Authorization Number) will be issued to you. Please write the RMA number in the appropriate box in the form on the back of this page. Please enclose the form with the returned product(s) and write the RMA# clearly on the package near the mailing label. No returns will be allowed for product returns that are not listed on the RMA.

## Returned Materials Authorization Form

If a problem with this product develops within the warranty period, please contact our Repair Department at 585-226-9500 option #3. When contacting us about a product you have purchased, please have the product's serial number readily available. If the product needs to be returned, you will be issued an RMA number (Returned Materials Authorization Number). No returns will be allowed for product returns that are not listed on the RMA. Please fill out the form below and enclose it with the returned product(s).

**MODEL:**

**Serial No.**

**RMA Number**

**Purchase Date**

 /  / 

**Install Date**

 /  / 

**Customer Name:** \_\_\_\_\_

**Company:** \_\_\_\_\_

**Address:** \_\_\_\_\_

**City:** \_\_\_\_\_ **ST:** \_\_\_\_\_ **ZIP:** \_\_\_\_\_

**Phone:** \_\_\_\_\_

---



---



---



---

**Dealer:** \_\_\_\_\_

**Installer:** \_\_\_\_\_